

datasheet

PRODUCT SPECIFICATION

1/2.3" color CMOS 16 megapixel(4608 × 3456) image sensor
With improved OmniBSI-2™ technology

OV16825

applications

- cellular phones

ordering information

- SD16825 (color, Lead-free) 48-Pin PLCC

features

- OminBSI-2™ (second generation BSI)
- support for image sizes:4608×3456 and below
- 16megapixel at 30fps
- 8-Lane LVDS/MIPI serial output inter
- two-wire serial bus control (SCCB)
- four-wire serial interface
- strobe output to control flash
- embedded one-time programmable (OTP) memory
- on-chip phase lock loop
- pixel binning with post processing
- frame exposure mode for still image with mechanical shutter
- capable of maintaining register values at power down
- programmable controls: gain ,exposure ,frame ,rate ,image size ,horizontal mirror ,vertical flip ,cropping ,RAW scaling , windowing ,and panning
- image control function : manual exp (MEC), Manual gain control (MGC) and automatic black level calibration (ABLC)
- image quality control : defect pixel correction
- low dark current
- support for black sun cancellation
- parallel I/O tri-state configurability and programmable polarity

key specifications (typical)

- active array size:** 4608 x3456
- power supply:**
 - core: 1.26V
 - analog: 2.8V
 - I/O: 1.8V/2.8V
- power requirements:**
 - active: table 1-1
 - standby: table 1-2
- temperature range:**
 - operating: -30°C to 70°C junction temperature
 - stable image: 0°C to 60°C junction temperature
- output interface :** up to 8 data lanes LVDS/MIPI output
- output formats:** RAW RGB data
- lens size:** 1/2.3"
- lens chief ray angle:** 29° non-linear
- input clock frequency:** 6~27 MHz
- shutter :** rolling
- max S/N ratio:** 36.4 dB
- dynamic range:** 68.6 dB @ 8x gain
- maximum image transfer rate:**
 - Table 2-1
- sensitivity:** 800mV/Lux-sec
- scan mode:** prgressive
- maximum exposure interval:** 1frame -4T_{line}
- pixel size:** 1.34 μm x 1.34 μm
- dark current:** 30e-/s @ 60°C junction temperature
- image area:** 6239.04 μm x 4673.92 μm
- package dimensions:** 13.4 mm x 13.4 mm(PLCC)

table of contents

1	signal descriptions	01
2	system level description	05
2.1	overview	05
2.2	architecture	05
3	format and frame rate	07
4	mechanical specifications	08
4.1	physical specifications	08
4.2	IR reflow specifications	09
5	optical specifications	10
5.1	sensor array center	10
5.2	lens chief ray angle (CRA)	11

1. signal descriptions

table 1-1 lists the signal descriptions and their corresponding pin numbers for the SD16825 image sensor. The package information is showing

table 1-1 signal descriptions (sheet 1 of 2)

Pad number	signal name	pad type	description	voltage
01	MDN7	I/O	LVDS/MIPI data 7 negative output	
02	MDP7	I/O	LVDS/MIPI data 7 positive output	
03	MDN5	I/O	LVDS/MIPI data 5 negative output	
04	MDP5	I/O	LVDS/MIPI data 5 positive output	
05	MCN1	I/O	LVDS/MIPI clock 1 negative output	
06	MCP1	I/O	LVDS/MIPI clock 1 positive output	
07	MDN4	I/O	LVDS/MIPI data 4 negative output	
08	MDP4	I/O	LVDS/MIPI data 4 positive output	
09	MDN6	I/O	LVDS/MIPI data 6 negative output	
10	MDP6	I/O	LVDS/MIPI data 6 positive output	
11	MDN3	I/O	LVDS/MIPI data 3 negative output	
12	MDP3	I/O	LVDS/MIPI data 3 positive output	
13	MDN1	I/O	LVDS/MIPI data 1 negative output	
14	MDP1	I/O	LVDS/MIPI data 1 positive output	
15	MCN0	I/O	LVDS/MIPI clock 0 negative output	
16	MCP0	I/O	LVDS/MIPI clock 0 positive output	
17	MDN0	I/O	LVDS/MIPI data 0 negative output	
18	MDP0	I/O	LVDS/MIPI data 0 positive output	
19	MDP2	I/O	LVDS/MIPI data 2 positive output	
20	MDN2	I/O	LVDS/MIPI data 2 negative output	
21	VN0	reference	internal analog reference	
22	VN1	reference	internal analog reference	
23	RESETB	input	system reset (active low with pull up resistor)	
24	PWDN	input	power down (active high with pull down resistor)	
25	AVDD	power	analog power	2.8V

table 1-1 signal descriptions (sheet 2 of 2)

Pad number	signal name	pad type	description	voltage
26	AGND	ground	analog ground	
27	DGND	ground	I/O ground	
28	DVDD	power	digital circuit power	1.26V
29	DOVDD	power	I/O power	1.8V
30	DGND	ground	I/O ground	
31	AVDD	power	analog power	2.8V
32	AGND	ground	analog ground	
33	VDDSW	input	DVDD power cut enable (active high with pull down resistor)	
34	GPIO3	I/O	general purpose I/O	
35	SID	input	SCCB slave address select	
36	SIO_D	I/O	SCCB interface data pin	
37	SIO_C	I/O	SCCB interface input clock	
38	FREX	I/O	frame exposure input /mechanical shutter output	
39	STROBE	I/O	frame exposure output indicator	
40	VH0	reference	internal analog reference	
41	VH1	reference	internal analog reference	
42	XVCLK	input	system clock input	
43	VSYNC	I/O	video output vertical signal	
44	HREF	I/O	video output horizontal signal	
45	SCK	input	4-wire interface input clock	
46	SDI	input	4-wire interface data input	
47	SDO	input	4-wire interface data output	
48	CSB	input	4-wire interface input select (active low with pull up resistor)	

Note1 VDDSW, SCK, SDI should be connected to DGND outside of module if unused , and CSB should be connected to DOVDD outside of module if unused .

Note2 VSYNC, HREF, GPIO3, STROBE, FREX , SDO can be floating if unused .

table 1-2 configuration under various conditions

signal name	RESET	after RESET release	software standby	hardware standby
RESETB	input	input	input	input
PWDN	input	input	input	input
VDDSW	input	input	input	input
STROBE	high-z	high-z	high-z by default (configurable)	high-z
FREX	high-z	high-z	high-z by default (configurable)	high-z
SIO_C	high-z	input	input	high-z
SIO_D	open drain	I/O	I/O	open drain
SDI	high-z	input	input	high-z
SCK	high-z	input	input	high-z
HREF	high-z	high-z	high-z by default (configurable)	high-z
VSYNC	high-z	high-z	high-z by default (configurable)	high-z
XVCLK	high-z	input	input	high-z
MCP(0~1)	high-z	high-z	LP1 in MIPI mode, high-z in LVDS mode by default (configurable in MIPI mode)	high-z
MCN(0~1)	high-z	high-z	LP1 in MIPI mode, high-z in LVDS mode by default (configurable in MIPI mode)	high-z
MDP(0~7)	high-z	high-z	LP1 in MIPI mode, high-z in LVDS mode by default (configurable in MIPI mode)	high-z
MDN(0~7)	high-z	high-z	LP1 in MIPI mode, high-z in LVDS mode by default (configurable in MIPI mode)	high-z

figure 1-1 pin diagram bottom view

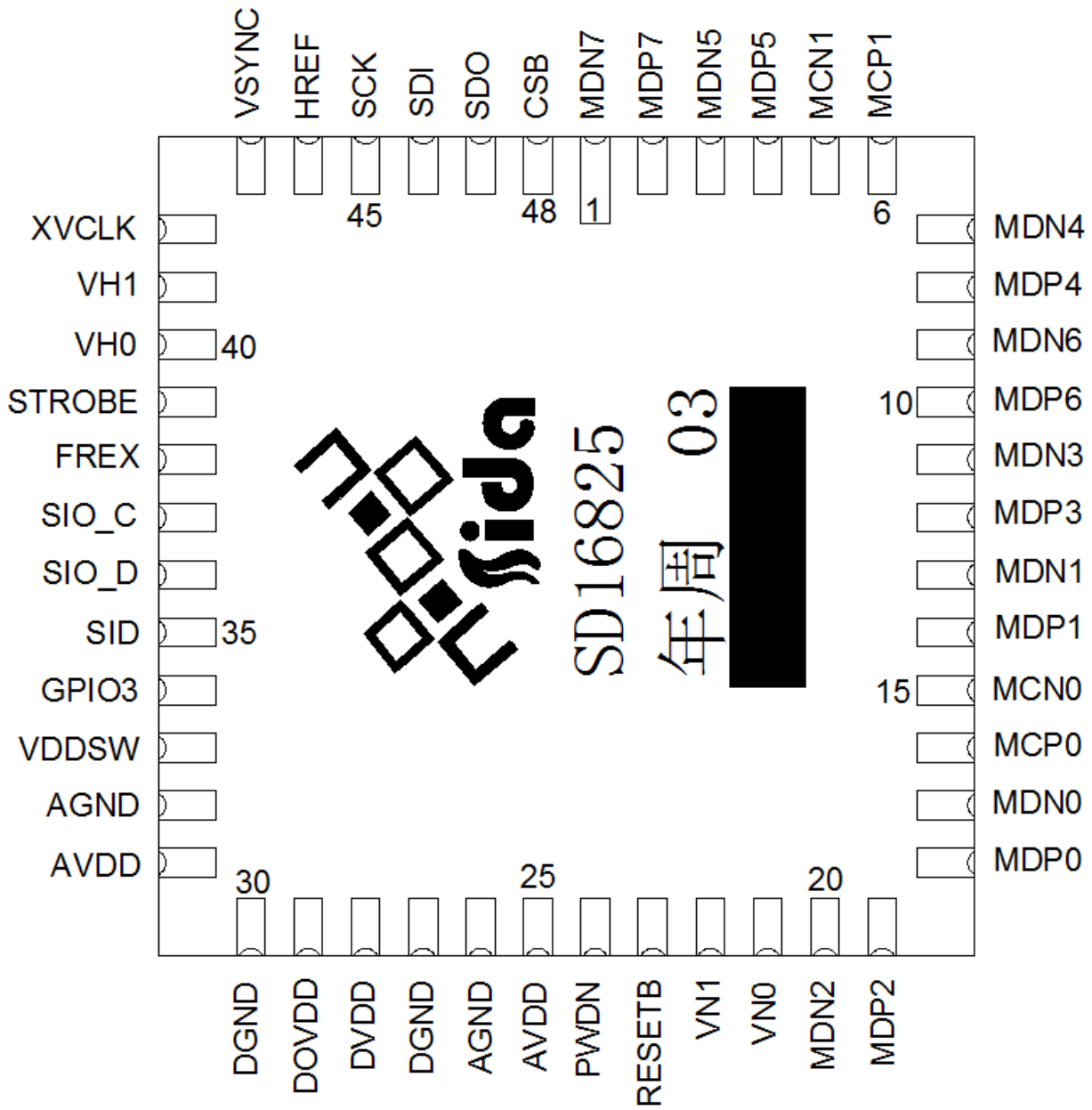

2. system level description

2.1 overview

The OV16825 color image sensor is a high performance ,16 megapixel RAW image sensor that delivers 4608×3456 at 30 fps using OminBSI-2™ pixel technology. It provides option for multiple resolution including full HD video at 120fps while maintaining full field of view. Users can program image resolution , frame rate, quality parameters and camera functions using the serial camera control bus (SCCB) or 4-wire serial interf.

The OV16825 is capable of delivering 30 fps at full resolution allowing burst photography at full 16 megapixel resolution. With a complete 16megapixel omage array ,the OV16825 contains all the image management function to ensure high quality imaging solutions for high resolution digital still camera , HD camcorders and mobile handsets.

ALL required image processing functions are programmable through the SCCB interface or 4-wire serial I/F . in addition , omnivision image sensors utilize proprietary sensor technology to improve image quality by reducing or eliminating common lighting/electrical sources of image contamination , such as fixed pattern noise , smearing, etc., to produce a clean, fully stable, color image.

2.2 architecture

The OV16825 sensor core generates streaming pixel data at a constant frame rate.

The timing generator outputs clocks to access the rows of the imaging array , precharging and sampling the rows of the array sequentially. In the time between precharging and sampling row ,the charge ing the pixls decrease with exposure to incident light .this is the exposure time in rolling shutter architecture .

The exposure time is controlled by adjusting the time interval between precharging and sampling. After the data of the pixels is the row has been sampled, it is processed through analog circuitry to correct the offset and multiply the data with corresponding gain. Following analog processing identification the ADC Chichester outputs 12-bit data for echinacea pixel in the array.

figure 2-1 OV16825 block diagram

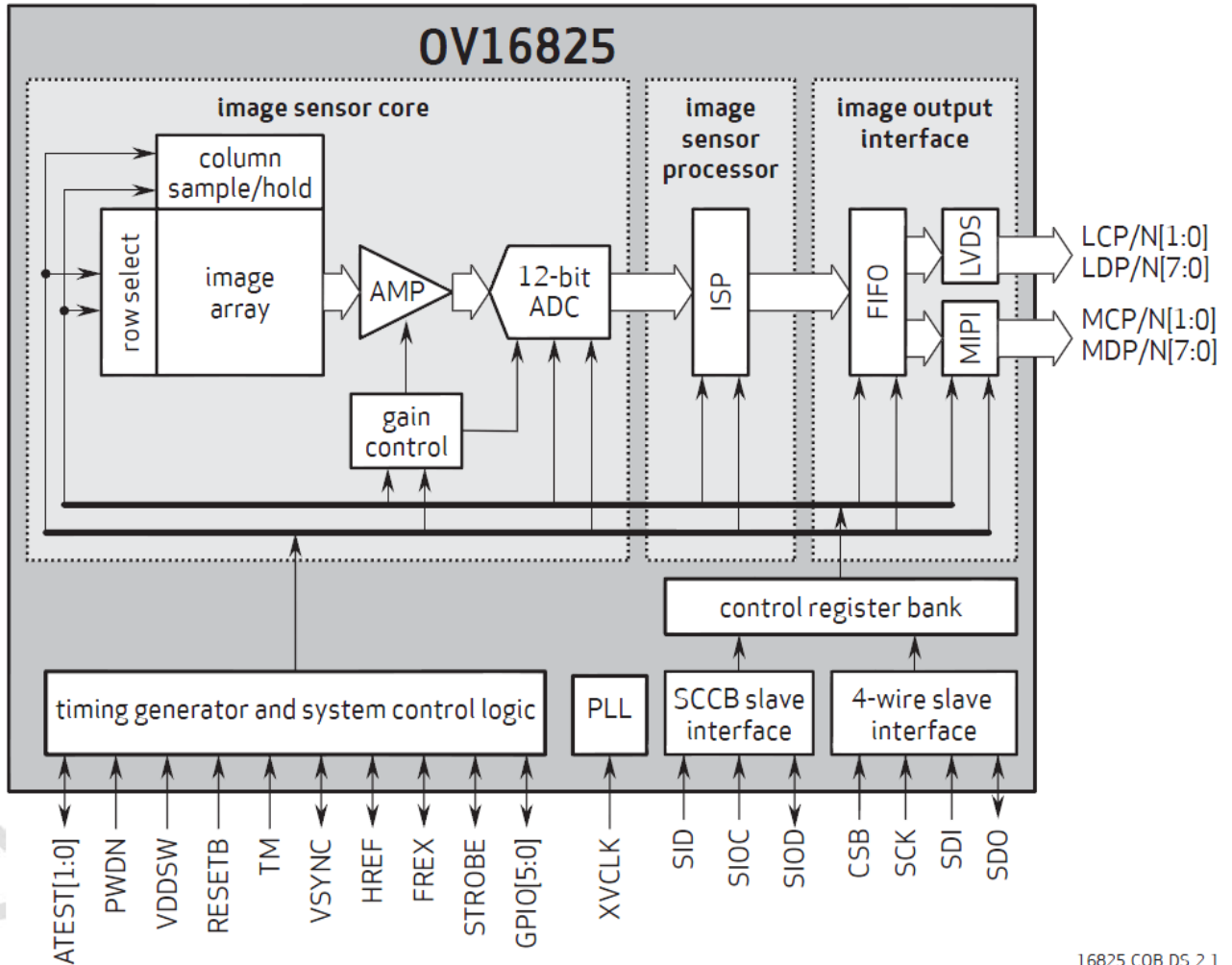

3. format and frame

The OV16825 supports up to 10/12-bit RAW output . the OV16825 can be programmed to output sensor data with:

- no binning (NB)
- horizontal binning only(HB)
- horizontal and vertical binning (HVB)

LVDS/MIPI frame rate

resolution	10-bit output		12-bit output		methodology	LVDS/MIPI data rate
	NB/HB	HVB	NB/HB	HVB		
4608x3456	30 fps 18 fps		30 fps		full	8-Lane @800Mbps/lane 4-Lane @800Mbps /Lane
3840x2160	60 fps 30 fps				cropping	8-Lane @800Mbps/lane 4-Lane @800Mbps /Lane
2304x1728	60 fps	30 fps			NB:2x2 skip HB:horizontal 2X binning , vertical 2X skip HVB: 2x2 binning	4-Lane @800Mbps /Lane
1920x1080	120 fps	60 fps			cropping first then : NB:2x2 skip HB:horizontal 2X binning , vertical 2X skip HVB: 2x2 binning	4-Lane @800Mbps /Lane
1536x1152	120 fps	30 fps			NB:3x3 skip HB:horizontal 3X binning , vertical 3X skip HVB: 3x3 binning	4-Lane @800Mbps /Lane

4 mechanical specifications

4.1 physical specifications

4.1figure package specifications

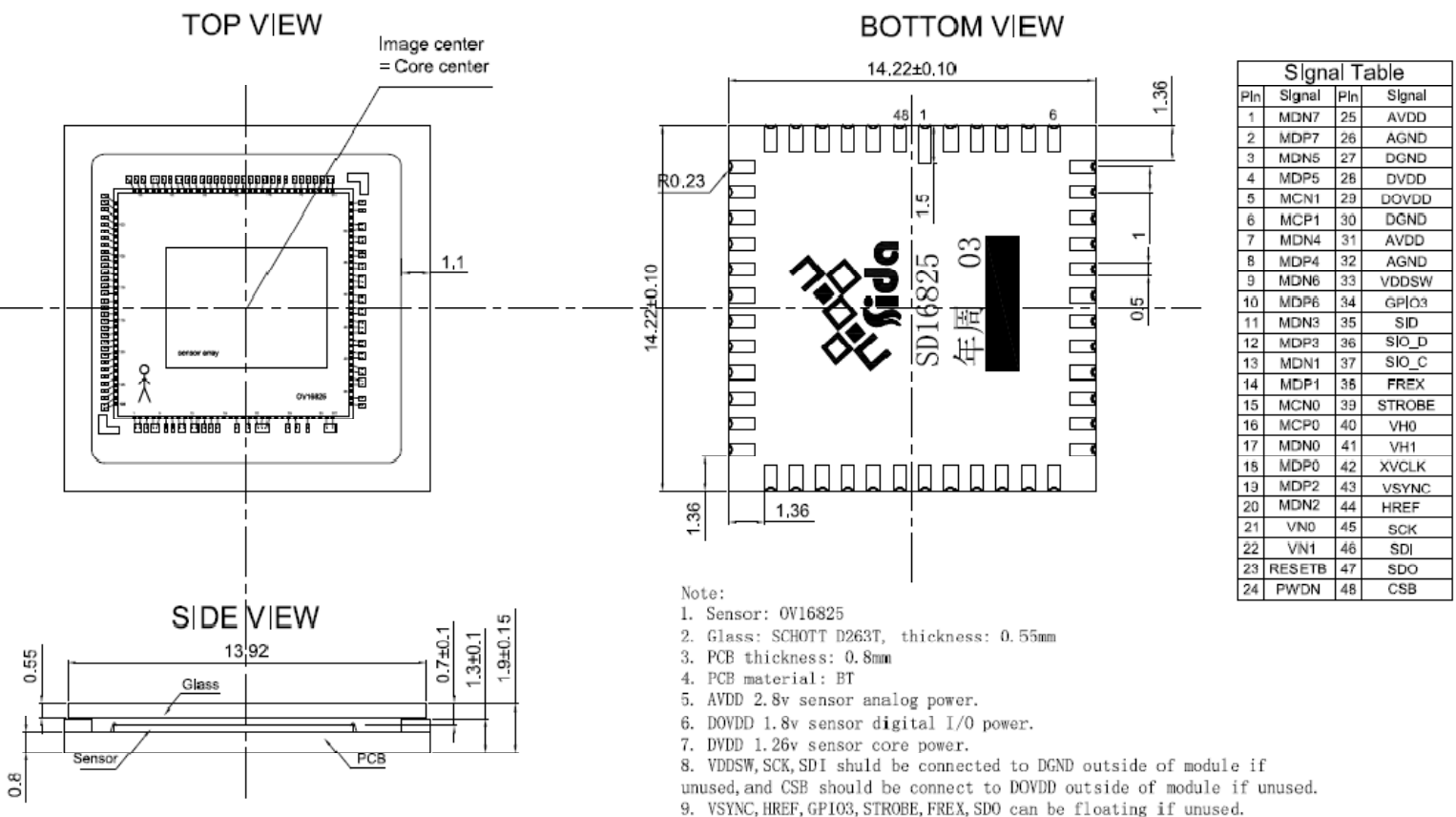

table 4-1 package dimensions (sheet 1 of 2)

dimensions	millimeters	inches
Package size	14.22±0.10 sq	0.5598±0.004 sq
Package height	1.9±0.15	0.075±0.006
Substrate base height	0.8±0.05	0.0315±0.002
Cavity size	12±0.20 sq	0.472±0.008 sq
Castellation height	0.65±0.05	0.026±0.002
Pin 1# pad size	0.50 x 1.50	0.0197 x 0.059
Pad size	0.50 x 1.00	0.0197 x 0.0394
Pad pitch	1.0±0.05	0.054±0.002
Package edge to first lead side	1.36±0.10	0.213±0.004
Glass size	13.92±0.10 sq	0.55±0.004 sq
Glass height	0.55±0.05	0.022±0.002
Die thickness	0.20±0.015	0.008±0.0006
Top of glass to image plane	0.70±0.10	0.028±0.004
Substrate height	1.30±0.10	0.051±0.004

4.2 IR reflow specifications

figure 4-2 IR reflow ramp rate requirements

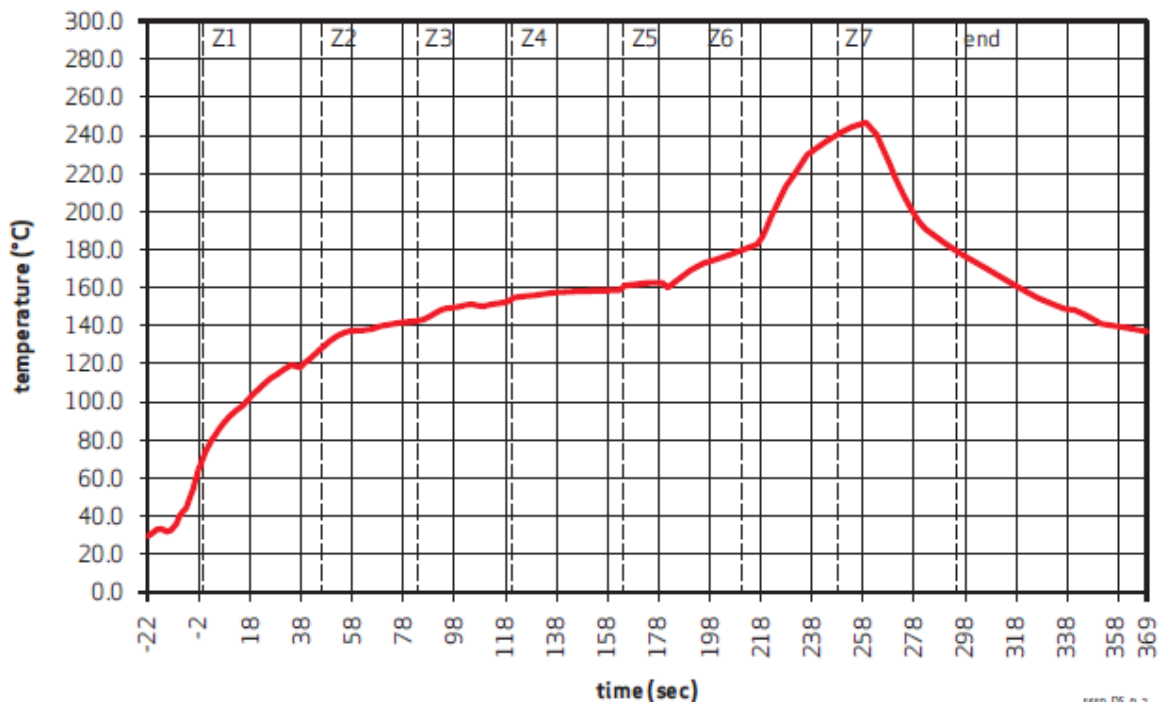

table 4-2 reflow conditions

condition	exposure
Average ramp-up rate (30°C to 217°C)	Less than 3°C per second
> 100°C	Between 330 – 600 seconds
> 150°C	At least 210 seconds
> 217°C	At least 30 seconds (30 ~ 120 seconds)
Peak temperature	245°C
Cool-down rate (peak to 50°C)	Less than 6°C per second
Time from 30°C to 245°C	No greater than 390 seconds

5 optical specifications

5.1 sensor array center

figure 5-1 sensor array center

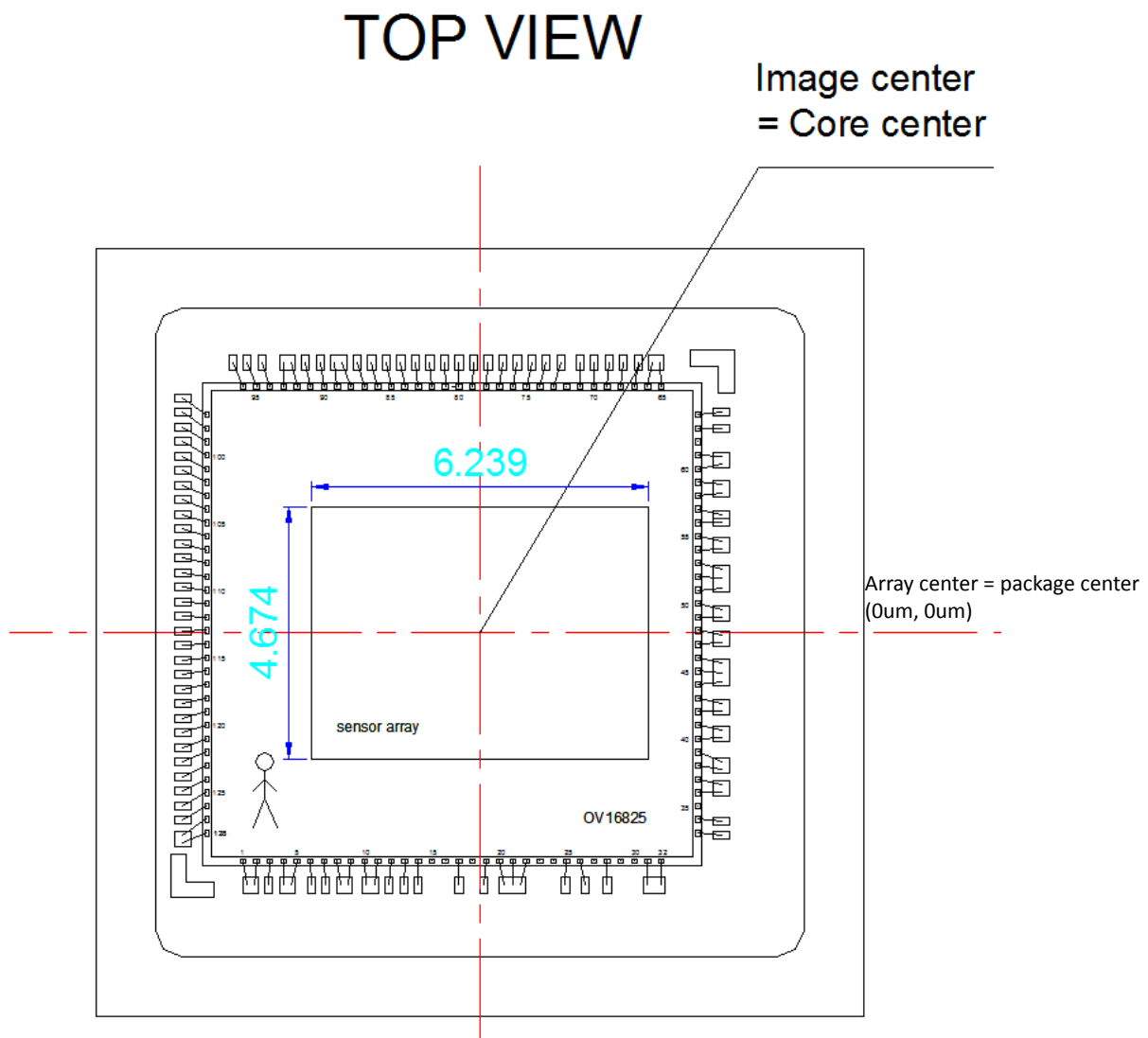

5.2 lens chief ray angle (CRA)

figure 5-2 chief ray angle (CRA)

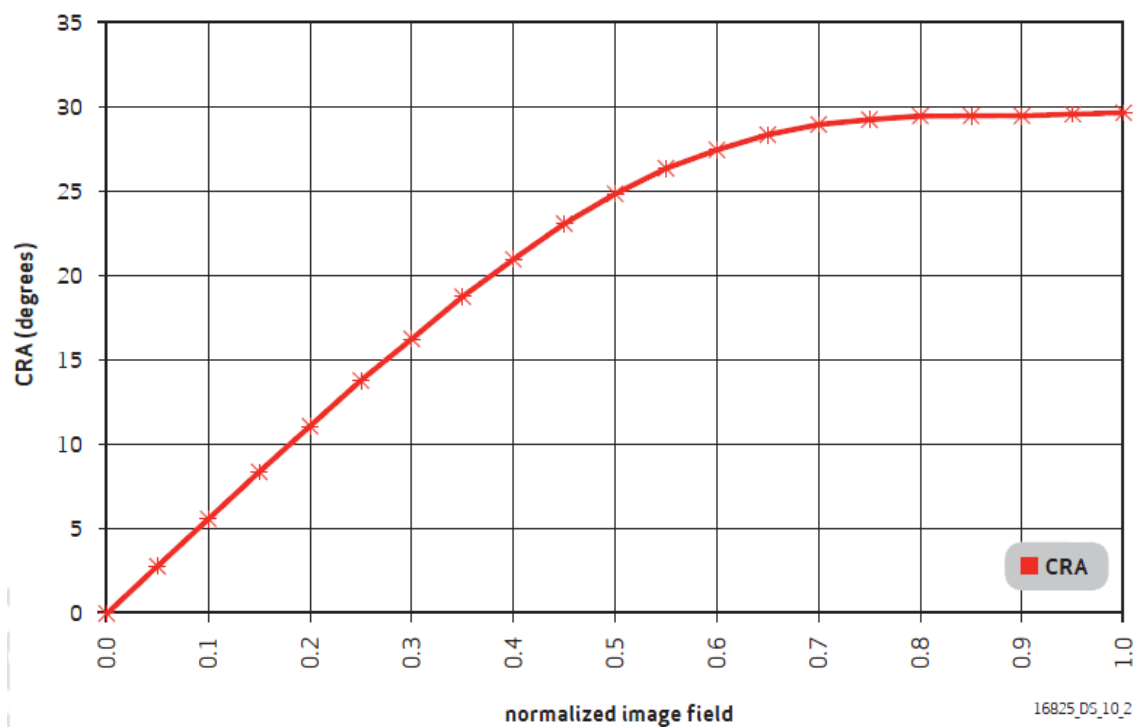

table 5-1 CRA versus image height plot (sheet 1 of 2)

Field (%)	Image height (mm)	CRA (degrees)
0	0	0
0.05	0.193	2.8
0.10	0.386	5.6
0.15	0.58	8.4
0.20	0.773	11.1
0.25	0.966	13.8
0.30	1.159	16.3
0.35	1.352	18.8
0.40	1.546	21
0.45	1.739	23.1
0.50	1.932	24.9
0.55	2.125	26.4
0.60	2.318	27.5
0.65	2.512	28.4
0.70	2.705	29

table 5-1 CRA versus image height plot (sheet 2 of 2)

Field (%)	Image height (mm)	CRA (degrees)
0.75	2.898	29.3
0.80	3.091	29.5
0.85	3.284	29.5
0.90	3.478	29.5
0.95	3.671	29.6
1.00	3.864	29.7